

Performance and quality made easy.



The Series 850 features an updated, minimal design aesthetic that gives retailers with limited budgets the ability to realize a “premium” visual merchandising experience. Offering scalable

security, dependable power up and InVue quality, combined with small form factor sensors, the Series 850 proudly has a premium look and delivers a great consumer experience.



FEATURES AND BENEFITS

- 1 Above counter POD simplifies installation
- 2 Common visual merchandising platform shared with additional InVue solutions
- 3 Native 2.1A power-up capability
- 4 Loud 95db alarm
- 5 Optional, easy to install brackets provide scalable deterrence



FEATURES AND BENEFITS (continued)

- 1 Small sensor provides minimal interference
- 2 Nightly removal capability by simply removing sensor from base
- 3 Serialized IR Key interface provides compatibility with InVue Access Manager zone control and auditing
- 4 Smaller strain relief improves aesthetics while maintaining high quality and reliability



IR ECOSYSTEM™

Series 850 is part of the exclusive InVue IR Ecosystem™, a storewide single key solution that improves customer service, increases sales and provides high theft protection.



- Handheld Electronics
- Electronic Accessories
- Secure Fixtures
- Package Protection
- Locked Cabinets
- Commercial Solutions



Series 850

SPECIFICATIONS

Series 850 Angled Stand & Micro USB Sensor (DCD100):

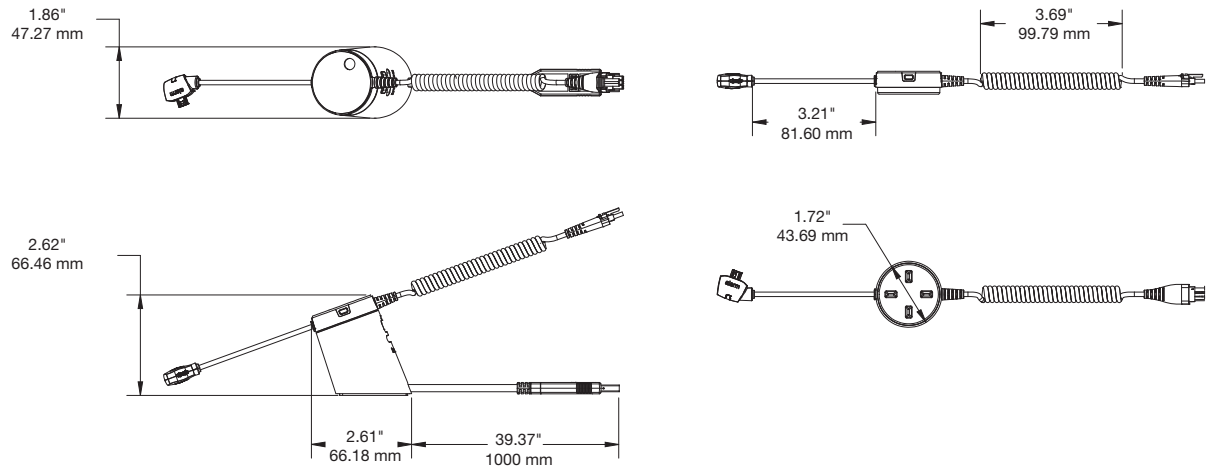

Series 850 Angled Stand & Type C Sensor (DCD101):

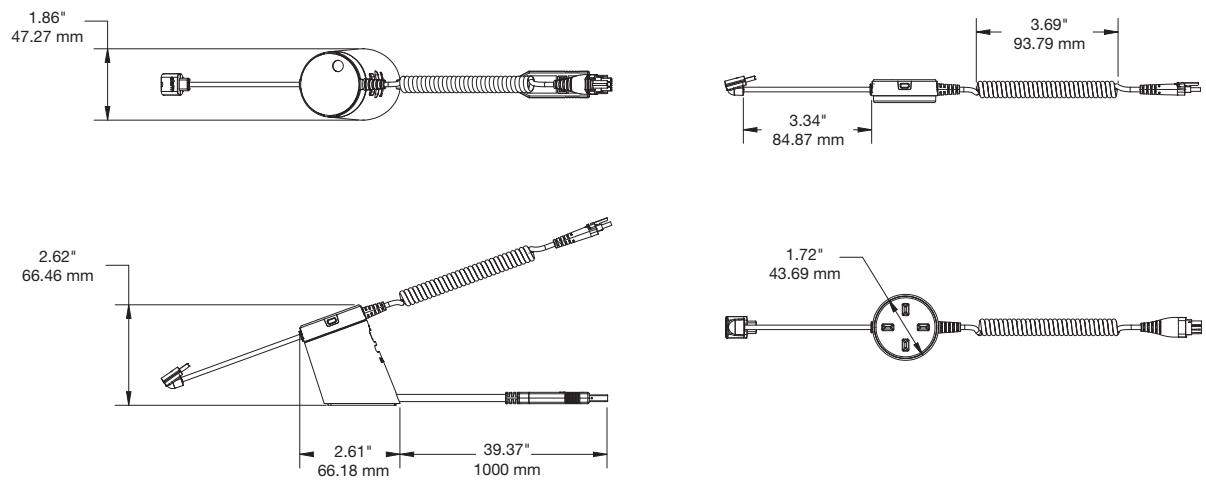

Series 850

SPECIFICATIONS

Series 850 Angled Stand & Lightning Sensor (DCD102):

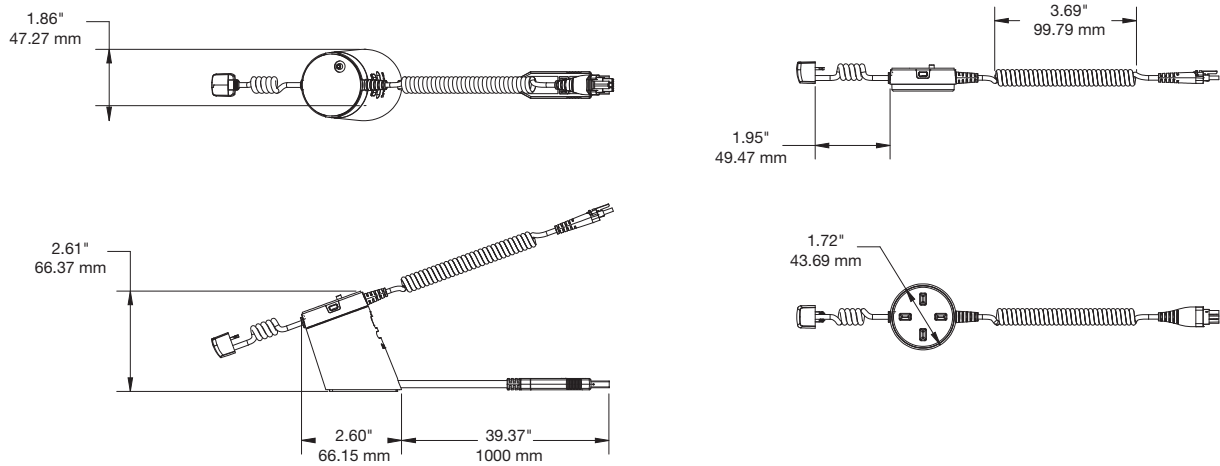

Series 850 Flat Stand & Micro USB Sensor (DCD103):

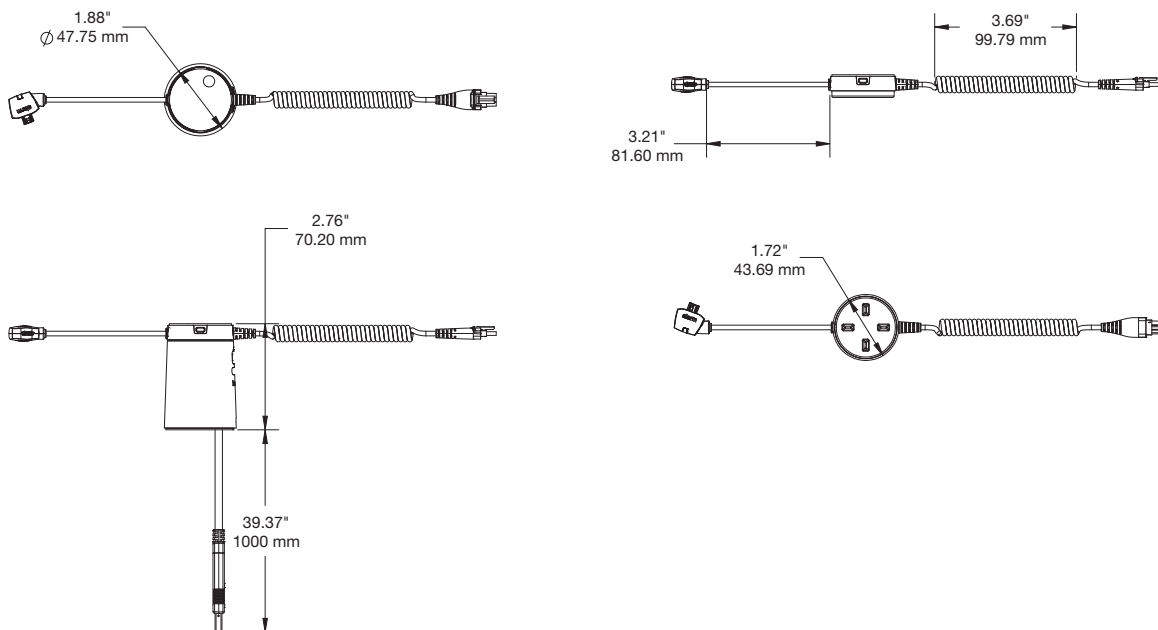

Series 850

SPECIFICATIONS

Series 850 Flat Stand & Type C Sensor (DCD104):

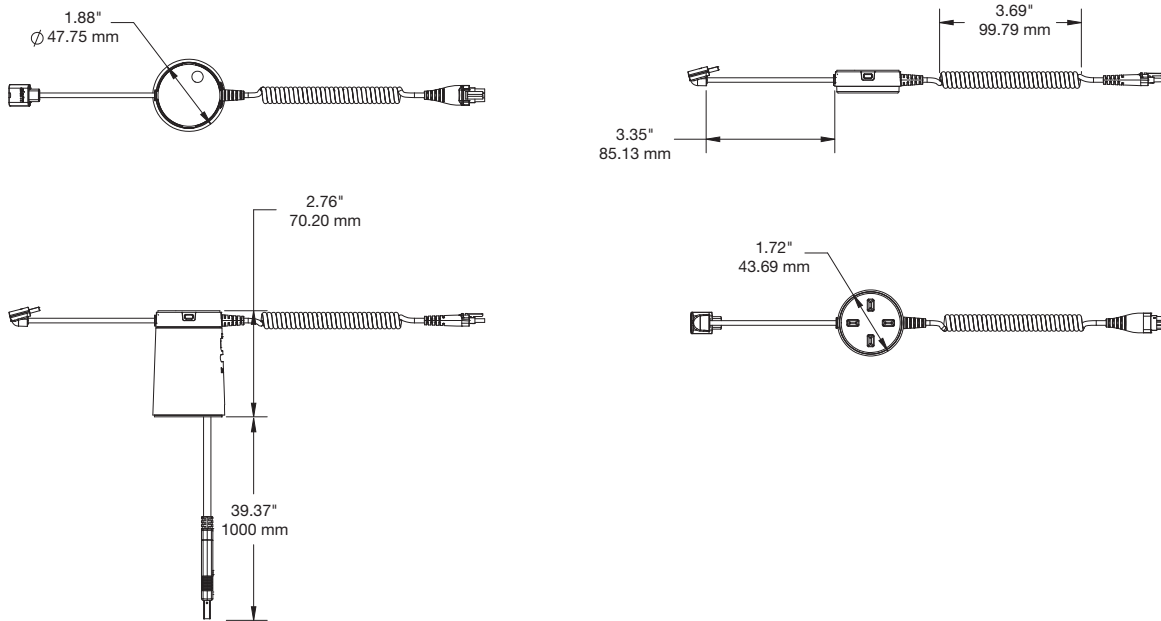

Series 850 Flat Stand & Lightning Sensor (DCD105):

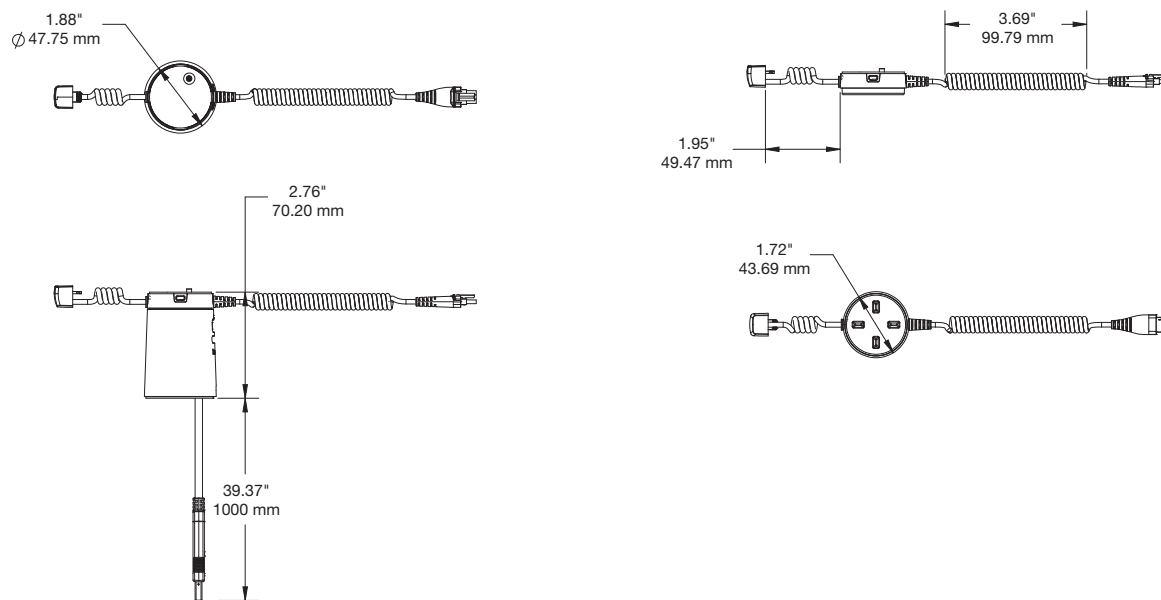

Series 850

SPECIFICATIONS

Series 850 Angled Stand & Lightning Sensor 2.1A (DCD108):

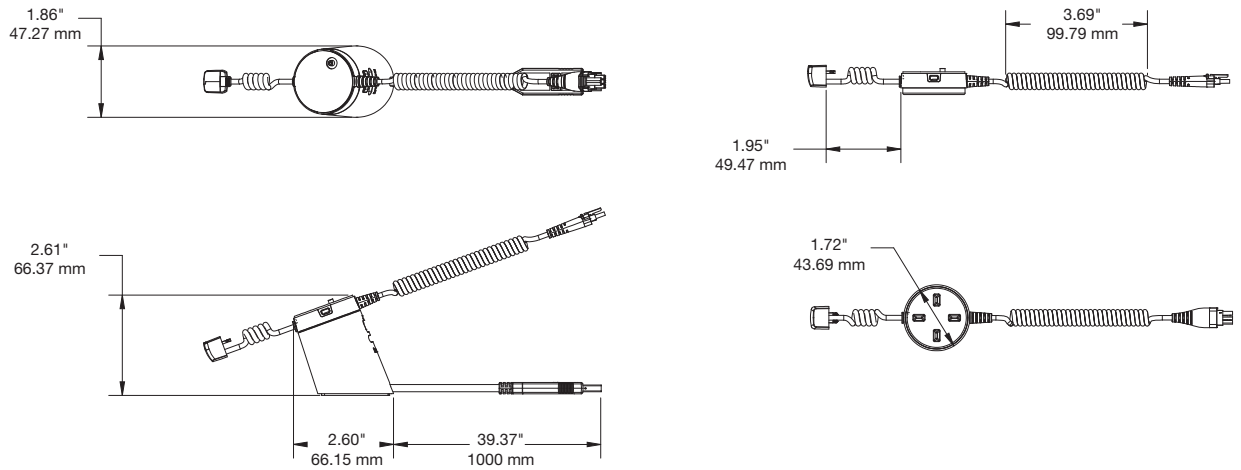

Series 850 Flat Stand & Lightning Sensor 2.1A (DCD109):

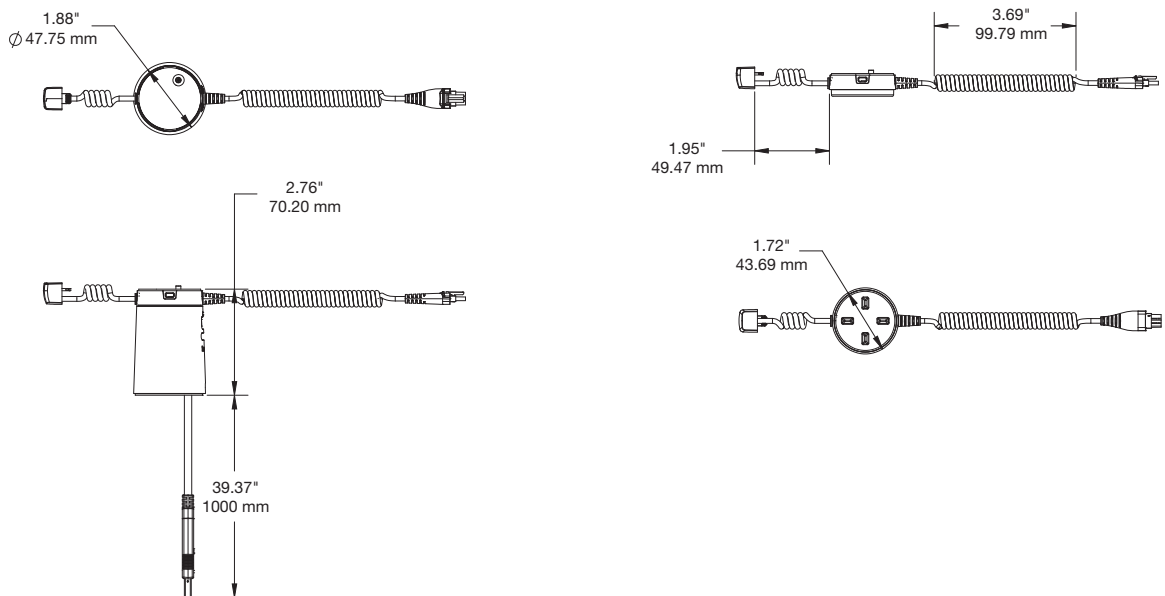

Series 850

SPECIFICATIONS

Sensor Clamp - 53-63mm wide; 17mm thick (HC7501-B):

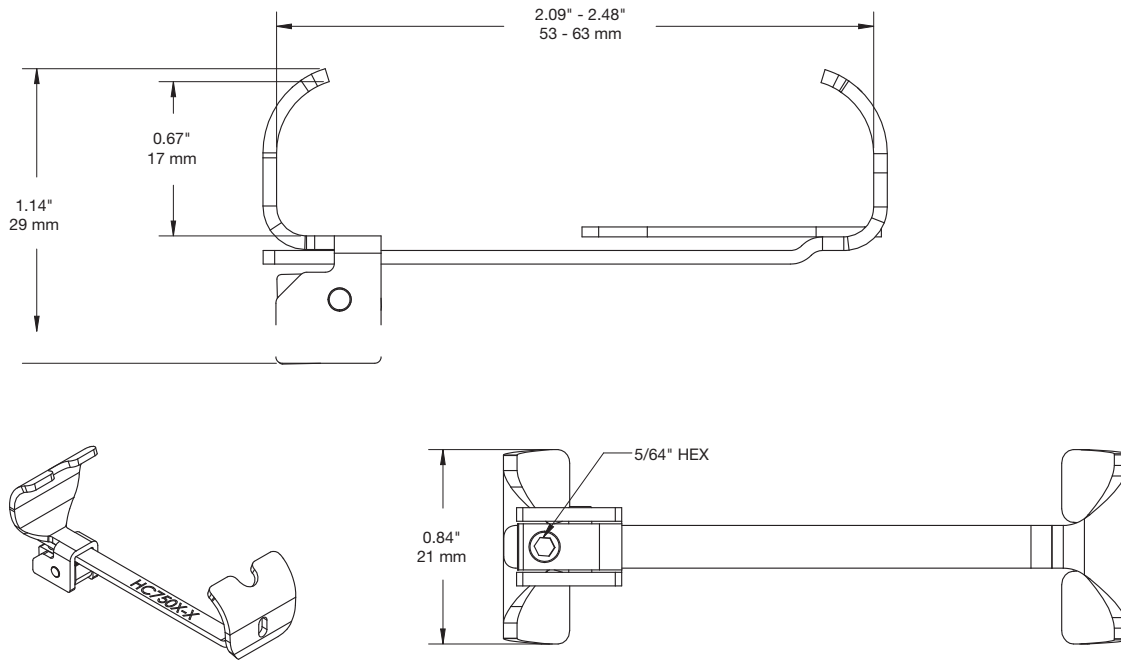

Sensor Clamp - 63-73mm wide; 17mm thick (HC7502-B):

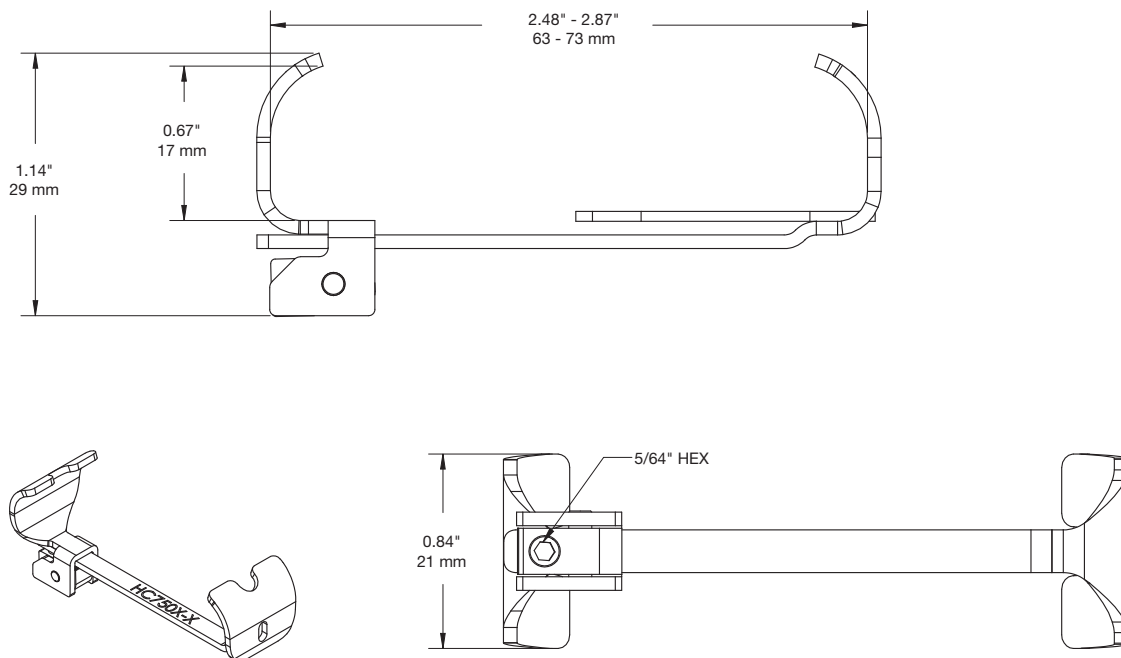

Series 850

SPECIFICATIONS

Sensor Clamp - 73-83mm wide; 10mm thick (HC7503-B):

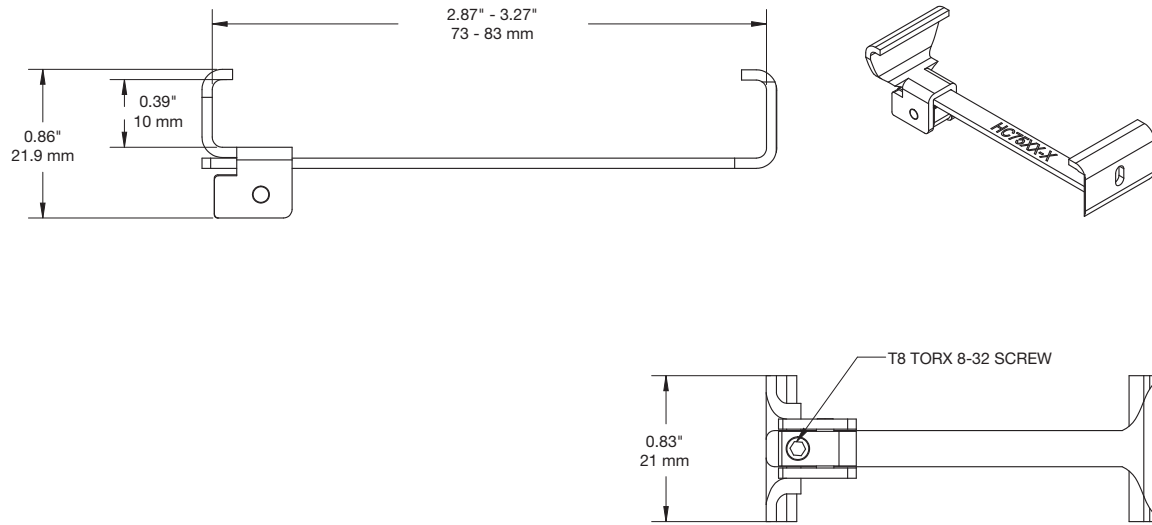

Sensor Clamp - 53-63mm wide; 10mm thick (HC7504-B):

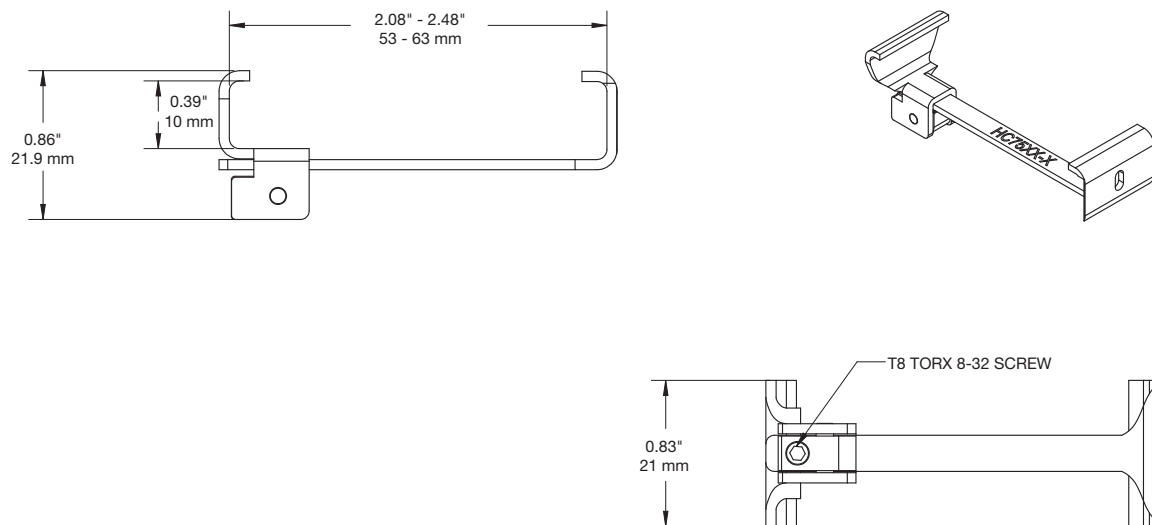

Series 850

SPECIFICATIONS

Sensor Clamp - 63-73mm wide; 10mm thick (HC7505-B):

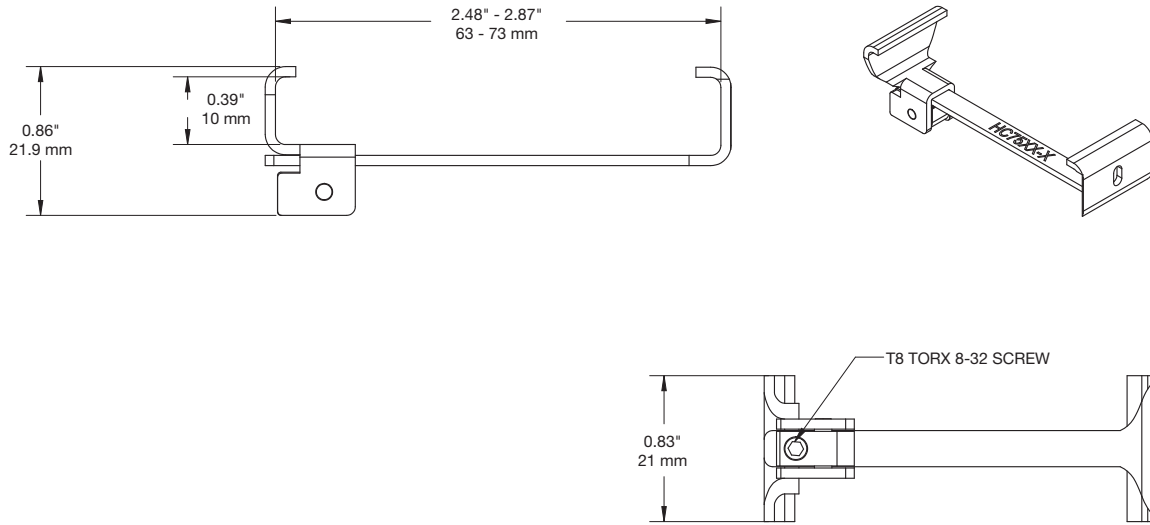

Sensor Clamp - 63-73mm wide; 10mm thick (HC7506-B):

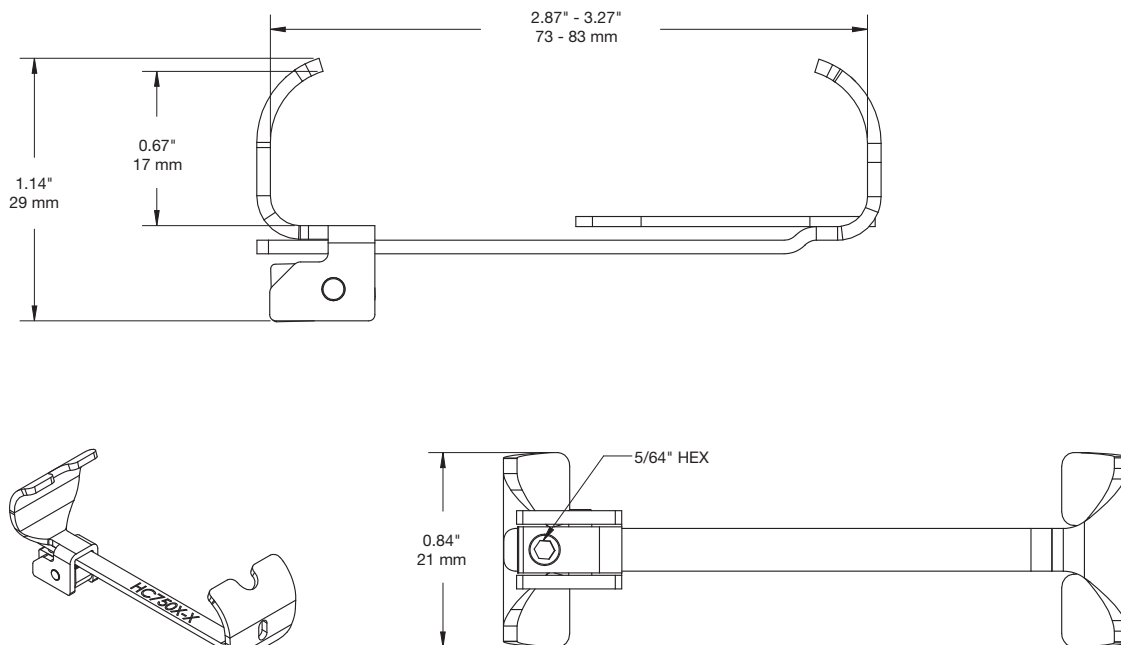

Series 850

SPECIFICATIONS

Sensor Clamp - 88-92mm wide; 10mm thick (HC7513-B):

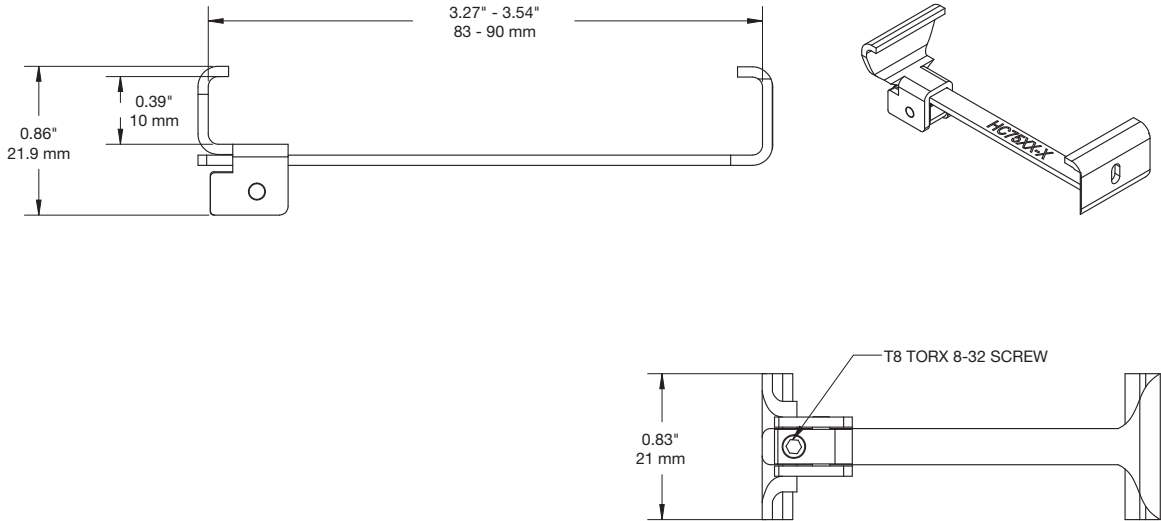

PRODUCT ORDERING

ORDER CODE	DESCRIPTION	NOTES
DISPLAY STAND AND SENSOR KITS		
DCD100-W DCD100-B	Series 850 Angled Stand & Micro USB Sensor - White Series 850 Angled Stand & Micro USB Sensor - Black	
DCD101-W DCD101-B	Series 850 Angled Stand & Type C Sensor - White Series 850 Angled Stand & Type C Sensor - Black	
DCD102-W DCD102-B	Series 850 Angled Stand & Lightning Sensor - White Series 850 Angled Stand & Lightning Sensor - Black	
DCD103-W DCD103-B	Series 850 Flat Stand & Micro USB Sensor - White Series 850 Flat Stand & Micro USB Sensor - Black	
DCD104-W DCD104-B	Series 850 Flat Stand & Type C Sensor - White Series 850 Flat Stand & Type C Sensor - Black	
DCD105-W DCD105-B	Series 850 Flat Stand & Lightning Sensor - White Series 850 Flat Stand & Lightning Sensor - Black	
DCD108-W DCD108-B	Series 850 Angled Stand & Lightning Sensor 2.1A - White Series 850 Angled Stand & Lightning Sensor 2.1A - Black	
DCD109-W DCD109-B	Series 850 Flat Stand & Lightning Sensor 2.1A - White Series 850 Flat Stand & Lightning Sensor 2.1A - Black	
REPLACEMENT STANDS AND SENSORS		
DCD106-W DCD106-B	Series 850 Replacement Angled Stand - White Series 850 Replacement Angled Stand - Black	
DCD107-W DCD107-B	Series 850 Replacement Flat Stand - White Series 850 Replacement Flat Stand - Black	
DCD200-W DCD200-B	Series 850 Replaceable Micro USB Sensor - White Series 850 Replaceable Micro USB Sensor - Black	
DCD201-W DCD201-B	Series 850 Replaceable Type C Sensor - White Series 850 Replaceable Type C Sensor - Black	
DCD202-W DCD202-B	Series 850 Replaceable Lightning Sensor - White Series 850 Replaceable Lightning Sensor - Black	
DCD203-W DCD203-B	Series 850 Replaceable Lightning Sensor 2.1A - White Series 850 Replaceable Lightning Sensor 2.1A - Black	
DNTX93	Scoop Blade Adhesive Removal Tool CT80/CT150	› Multitool is required (AF6313)
REPLACEMENT ADHESIVES		
ADH2120	Series 850 Angled Stand Replacement Adhesive	› 6 pack
ADH2159	Series 850 Flat Stand Replacement Adhesive	› 6 pack
ADH2119	Series 850 Sensor Replacement Adhesive	› 8 pack



PRODUCT ORDERING

ORDER CODE	DESCRIPTION	NOTES
BRACKETS		
HC7501-B	Sensor Clamp - Black	› 53-63mm wide; 17mm thick
HC7502-B	Sensor Clamp - Black	› 63-73mm wide; 17mm thick
HC7503-B	Sensor Clamp - Black	› 73-83mm wide; 10mm thick
HC7504-B	Sensor Clamp - Black	› 53-63mm wide; 10mm thick
HC7505-B	Sensor Clamp - Black	› 63-73mm wide; 10mm thick
HC7506-B	Sensor Clamp - Black	› 73-83mm wide; 17mm thick
HC7513-B	Sensor Clamp - Black	› 88-92mm wide; 10mm thick
DIGITAL INTERFACE & CCTV		
DGD405	90-Degree DIB Cable	
HC4417-PO	PB 18 Volt - Power Box	
YLR18V	DC Power Supply - 18V DIB/PIB	
YR5V12	DIB 12 Port - 5V	
YLR5V	DC Power Supply - 5.3V DIB/PIB	
POWER SUPPLIES		
PS515-US	USB-A Power Supply - US	
PS515-UK	USB-A Power Supply - UK	
PS515-EU	USB-A Power Supply - EU	
PS515-JPN	USB-A Power Supply - JPN	
PS515-KR	USB-A Power Supply - KR	

invue.com

©2018 InVue Security Products. No endorsement of InVue products has been made by any of the manufacturers of the products shown. Product is sold pursuant to InVue's warranty which can be found at www.invue.com/warranty.

THE AMERICAS 704.752.6513 • 888.55.INVUE

EUROPE, MIDDLE EAST & AFRICA +31.23.8900150

ASIA PACIFIC +852.3127.6811

